

MBPCX 31 T2 1,5kW Zone 2: FAN (Ex h IIB T4 Gc) + MOTOR (Ex db IIC T4 Gb) (502303119XD)

GENERAL DATA



PLASTIC ATEX FAN WITH FORWARD IMPELLER

MANUFACTURING FEATURES

- Housing made of PP-el plastic (for models size 35 and equal to or greater than size 45) other models PE-el casing
- Forward curved impeller in PP plastic.
- Motor support made of rolled steel sheet with polyester powder finishing coat.
- Stainless steel nuts and bolts.
- Standard asynchronous squirrel-cage motor, IP-55, class F insulation. Standard voltages 230/400V 50Hz for three phase motors up to 4kW and 400/690V 50Hz for higher powers. Equipped with ATEX motors

- Available positions (to be indicated in case of order): LG270, LG0, LG45, LG90, LG135, LG180, LG225, LG315, RD0, RD45, RD90, RD135, RD180, RD225, RD270, RD315.
- The indicated codes correspond to the model in position LG270

APPLICATIONS

Designed for inline installation, they are suitable for:

- Corrosive air transport.
- Chemical and petrochemical industry.
- Laboratories and gas cabinets.
- General ventilation in closed environments classified as ATEX zone 2.
- Maximum temperature of transported air: If it is clean air 70°C, other depends on the gas (see table in documentation)

UNDER REQUEST

- 60Hz fans and special voltages fans.
- Stainless steel motor support.

In compliance with the ATEX Directive 2014/34/UE. Certified ATEX IIIG with certified ATEX motor for areas 2 (gas)

PERFORMANCE CURVE

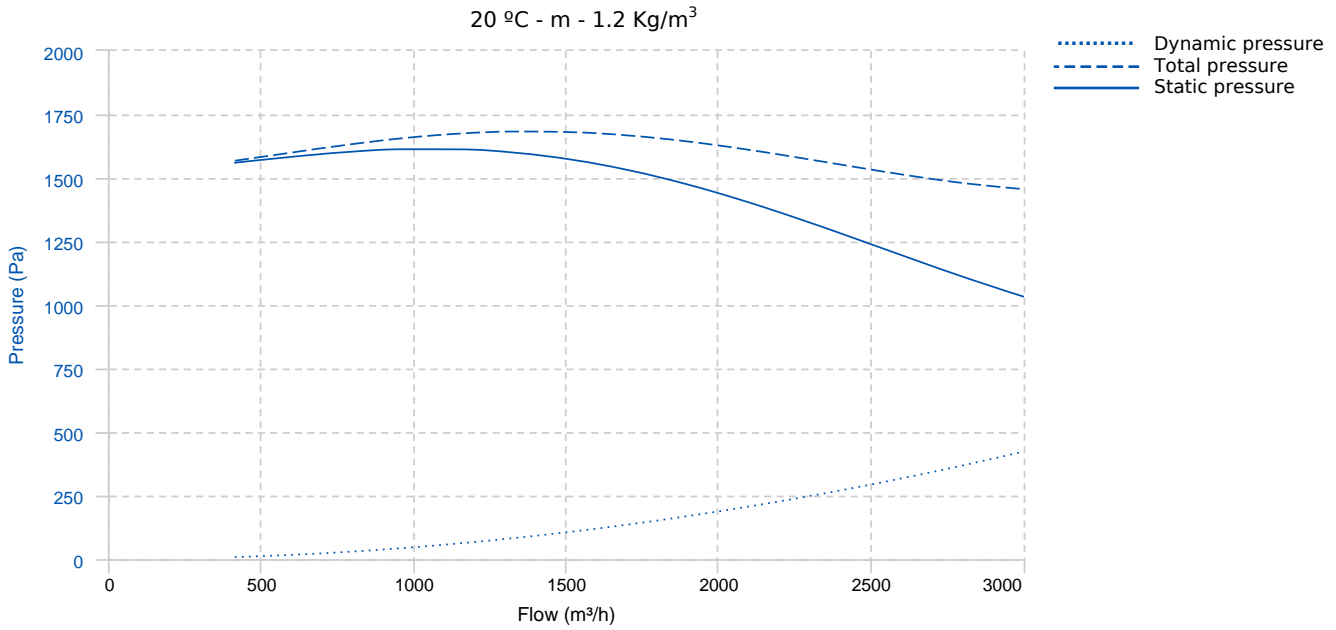

TECHNICAL DATA

Fan							
RPM	2850	Approx. weight	44 kg	Max. Flow	3000 m³/h		
Motor							
Power	1,5 kW	RPM	2850	I max. (400V)	3,95 A	Size	90S
Approx. weight	13 kg	Efficiency (%)	73 %	FP	0.8		

DIMENSIONS

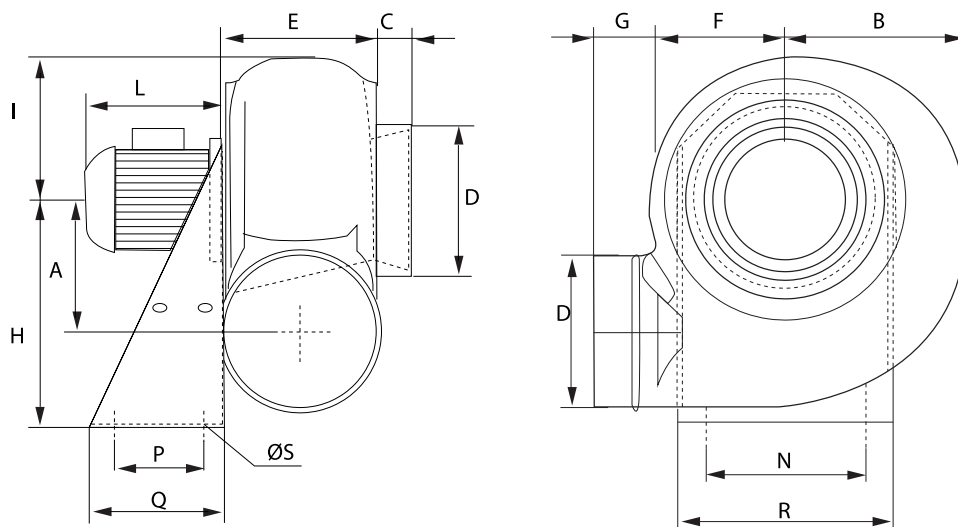

Dimensions (mm)

A	230	B	310	C	40	DØ	200	E	170
F	220	G	60	H	410	I	245	L	290
N	320	P	150	Q	230	R	355	ØS	11

WIRING DIAGRAM

230V

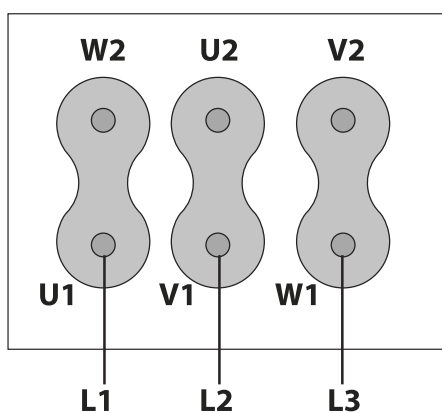

400V

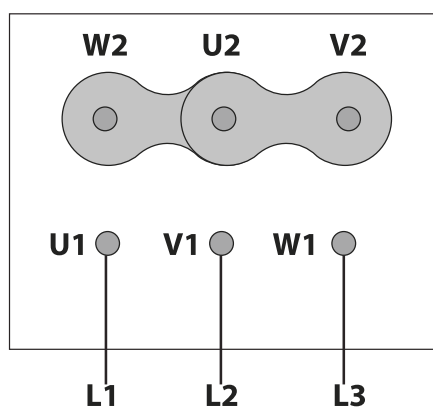

ACCESSORIES



ANTI-VIBRATING FLANGE 400^º/2H
BA-400 20
REF: 960002066



ATEX SWITCH
INT 16 ATEX
REF: 510200016X



DIFUSOR GRID
DG Ø200
REF: DG200



ADJUSTABLE DAMPER
AD Ø200
REF: AD-200

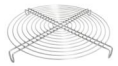

STAINLESS STEEL PROTECTION GRID
RPI Ø200
REF: RPI200



ANTI-VIBRATION BLOCK
AV 2
REF: AV-2



FREQUENCY SPEED CONTROLLER
SFC 400 III 5A *
REF: SFC400III5



ANTI-VIBRATION SPRING BLOCK
AVS (GENERIC)



ANTI-VIBRATION JOINT
JE 45
REF: A-300719201



PVC FLEXIBLE JOINT
FJ Ø200
REF: FJ-200



CIRCULAR GRAVITY DAMPER
CSC Ø200
REF: CSC200



DRAIN PLUG
PD 1
REF: PD1



WALL SUPPORT
WS 1
REF: WS1



FREQUENCY SPEED CONTROLLER
SFC 230 I 7A *
REF: SFC230I007



ANTI-VIBRATION RUBBER BLOCK
AVR (GENERIC)

SPARE PARTS

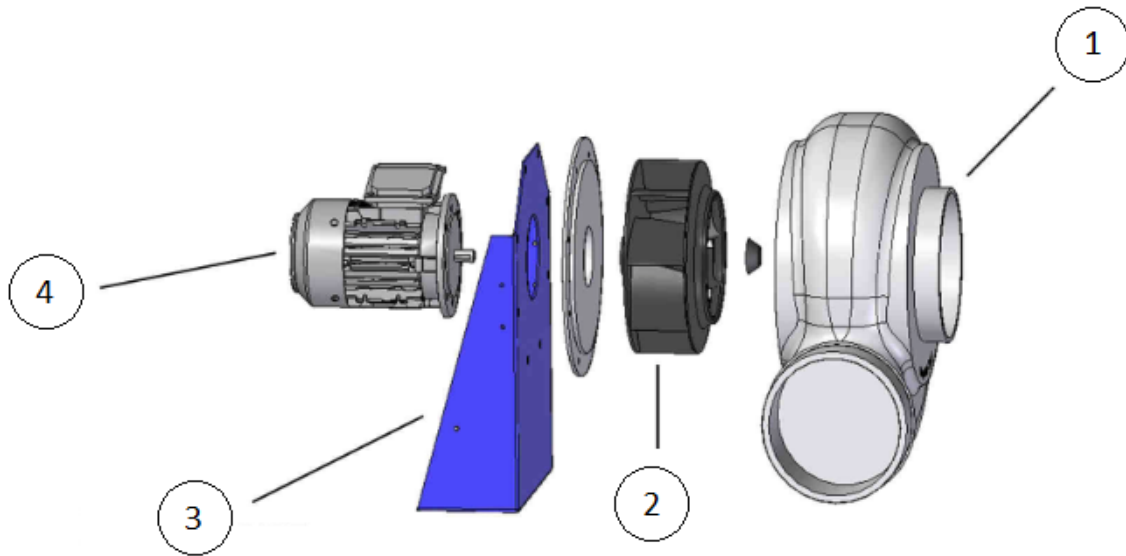

	Code	Model	Qty
1	T03103119	IMPELLER MBPCX 31 T2 1,5 kW LG	x1
2	721601047	MOTOR 1,5KW 3000 B5 230/400V II2G IIC T4 Ex-d Gb IP66	x1